

THIS DRAWING IS UNPUBLISHED. RELEASED FOR PUBLICATION, 19 .  
 © COPYRIGHT 19 BY AMP INCORPORATED. ALL INTERNATIONAL RIGHTS RESERVED.

LOC	DIST	P	F	ZONE	LTR	REVISIONS		
AF	50				C	DESCRIPTION	DATE	APPD
						REDRAWN PER 0710-0118-96	4/1/96	JR/JH

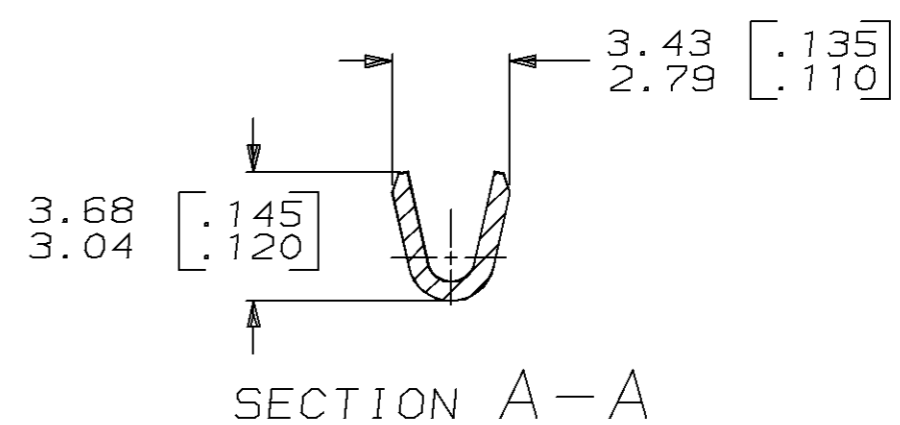
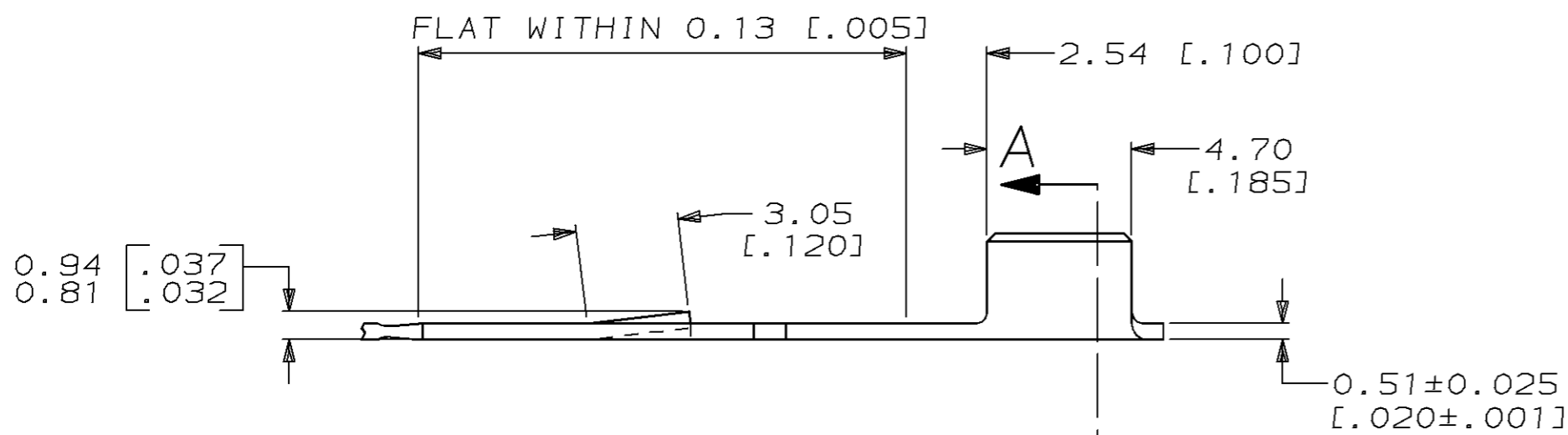
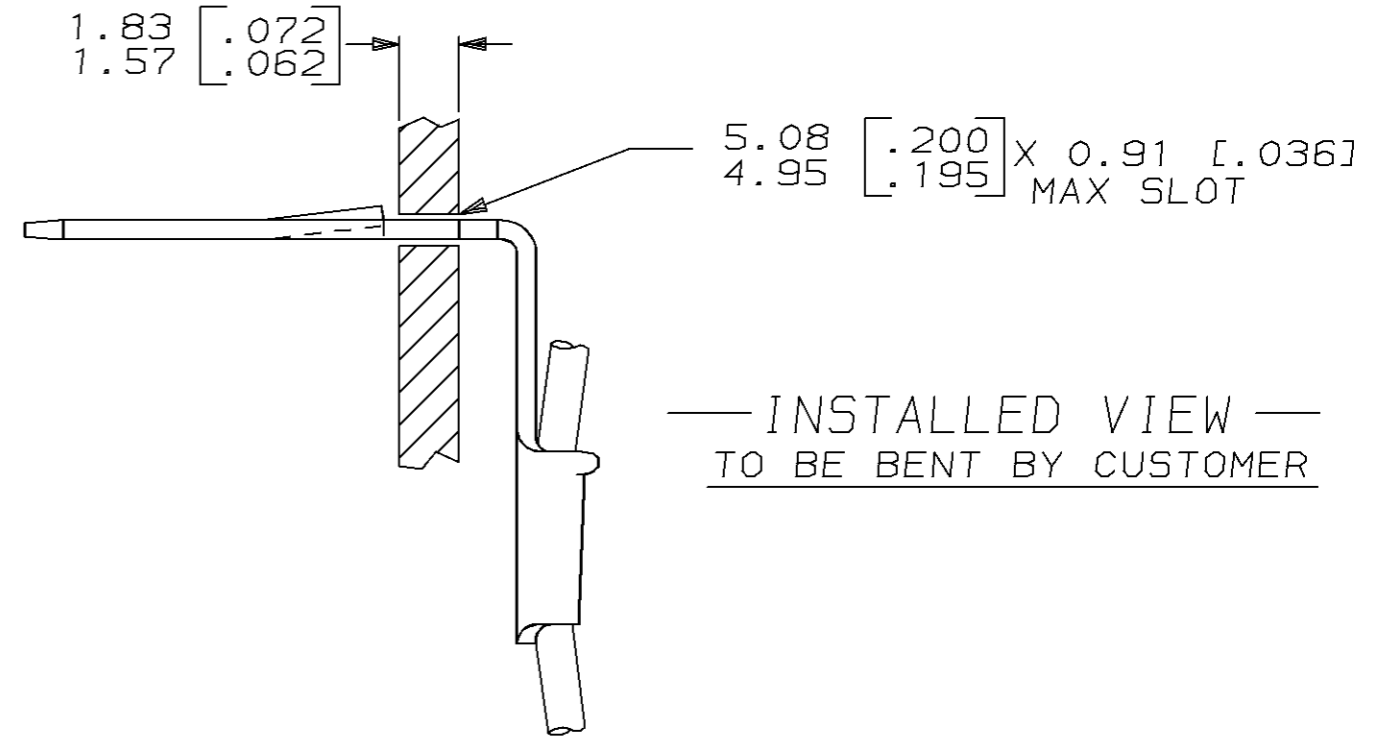
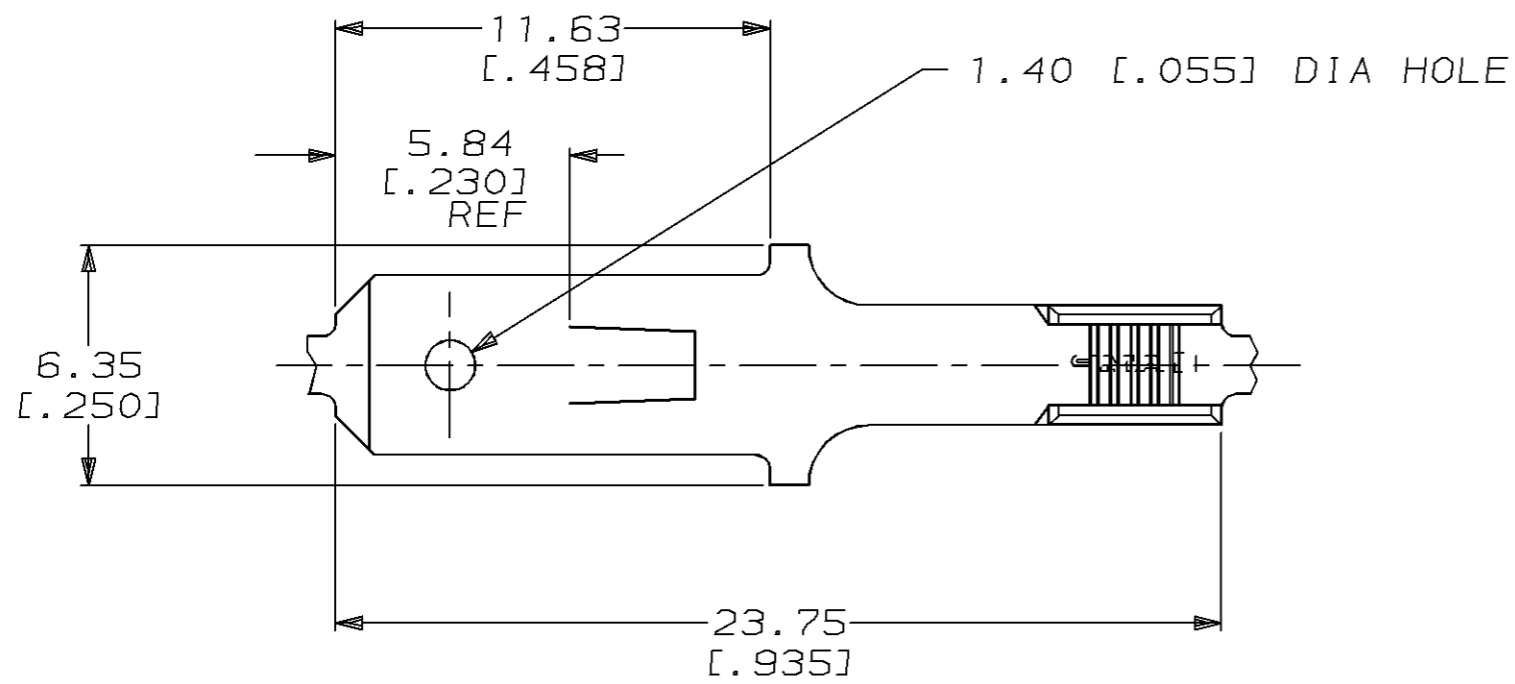

- 1 CONTINUOUS STRIP ON REELS.
- 2 1.29-0.72mm DIA [#21-#16 MAG] WIRE SIZE.
- 3 REVERSE REEL OF 63095-1.

3	63095-2
	63095-1
	PART NO

DO NOT SCALE PRINT. UNLESS SPECIFIED DIMENSIONS IN mm [INCHES] TOLERANCES ON: 2 PLC DEC ± 0.38 [.015] 3 PLC DEC ± - ANGLES ± -	DR 4/1/96 JR RUTH	<b>AMP</b> AMP Incorporated Harrisburg, PA 17105-3608
	CHK 4/1/96 MS FEHER	
	APPD 4/1/96 J HUZVAR	
	APPD 4/1/96 V KARABOCIEVSKY	
MATERIAL 082 BRASS	PRODUCT SPEC -	NAME TAB, FASTON, AMPLIVAR, 4.75 [.187] SERIES
FINISH 0.002032 [.000080] MIN TIN	APPLICATION SPEC -	SIZE B
	WEIGHT -	CAGE CODE 00779
		DRAWING NO C-63095
		SCALE 5:1
		SHEET 1 OF 1

THIS DRAWING IS A CONTROLLED DOCUMENT FOR AMP INCORPORATED. IT IS SUBJECT TO CHANGE AND THE CONTROLLING ENGINEERING ORGANIZATION SHOULD BE CONTACTED FOR THE LATEST REVISION.